

PORSCHE

RALLY TROPHY BENELUX

SPORTING REGULATIONS 2026

Name of the Series:
Porsche Rally Trophy Benelux

Status of the Series : National

Foreword:

CUP CHALLENGE BENELUX B.V., hereinafter called the Trophy Organiser, is hosting the Porsche Rally Trophy Benelux for 2026.

Organisation Cup Challenge Benelux B.V.
Maastricht Randwyck
Robert Schumandomein 2
6226 ES Maastricht
The Netherlands
T+31 (0)43 790 1000

Contact Yves Matton – Series Manager
E-Mail: yves.matton@prospeed.be
Website: rallytrophybenelux.com

 Julien Frère – Trophy Coordinator
Mobile : +32 479 97 28 71
E-Mail : julien.frere@prospeed.be

Table des matières

1	INTRODUCTION.....	4
2	ORGANISATION.....	4
2.1	Series Organiser	4
2.2	Parent ASN	5
2.3	ASN Visa/ Registration Number	5
2.4	The Organising Committee.....	5
2.5	The Sporting Committee	5
3	DEFINITIONS	6
4	APPLICABLE REGULATIONS AND LEGAL BASIS OF THE TROPHY	7
4.1	Porsche Rally Trophy Benelux Code of Conduct.....	7
4.2	Regulations and documents applicable.....	8
4.3	Entry into Force and Amendments to the Regulations	9
4.4	Official Language and Interpretation	9
5	CALENDAR.....	9
6	ENTRIES.....	10
6.1	Eligibility – General Provisions	10
6.2	Entries and Closing Date for Entries	10
6.3	Representation of the Competitor	10
6.4	Acceptance and Refusal of Entries	10
6.5	Drivers	11
6.5.1	Classified Drivers.....	11
6.5.2	Masters Drivers.....	11
6.5.3	Non-classified Drivers	11
6.5.4	“Guest / VIP” Drivers	12
6.6	Entry Fees and Conditions.....	12
6.6.1	Entry Modalities.....	12
6.6.2	Entry Fee.....	12
6.6.3	Included Services and Benefits :	13
	The entry fees include, for each event, the following services and benefits:.....	13
6.6.4	Optional Benefits at Preferential Rates	13
6.7	Entries for the Individual Rallies	14
6.8	Communication with Competitors	14
7	ELIGIBLE VEHICLES AND EQUIPMENT	14
7.1	Eligible Vehicles.....	14
7.2	General Conditions for Vehicle Eligibility	14
8	ADVERTISING, IDENTIFICATION AND USE.....	15
8.1	Car Identification.....	15
8.2	Use of Rights	15
9	SERVICE PARK	15
10	SPECIFIC TECHNICAL CHECKS.....	16
11	STARTING ORDER	16

Porsche Rally Trophy Benelux – Sporting Regulations 2026

12	PODIUM CEREMONY	16
13	CLASSIFICATIONS AND POINTS ALLOCATION	17
13.1	General Provisions	17
13.2	Points Allocation – Drivers’ Classification	17
13.3	Power Stage – Drivers’ Classification	17
13.4	Points Allocation – Masters Classification.....	18
13.5	Points Allocation – Teams Classification	18
13.6	Particular Case of Permanent Interruption of a Rally	19
13.7	Final Classifications of the Porsche Rally Trophy Benelux.....	19
13.7.1	Drivers’ Final Classification	19
13.7.2	Masters Final Classification.....	20
13.7.3	Teams Final Classification	20
14	PRIZES AND AWARDS	20
14.1	General Provisions	20
14.2	Prizes per Round	21
14.2.1	Tyres Allocation	21
14.2.2	Entry Fee Reimbursement.....	21
14.2.3	Special case of permanent interruption of a rally	21
14.3	End-of-Season Awards	21
14.4	Official End-of-Season Prize-Giving Ceremony	22
15	LIABILITY, INSURANCE AND DISCLAIMER.....	22
16	GOVERNING LAW AND JURISDICTION	22

1 INTRODUCTION

The Porsche Rally Trophy Benelux (PRTB), hereinafter called the Trophy, is organised in conformity with the provisions of the FIA International Sporting Code and its appendices (hereinafter referred to as the “Code”), as well as the National Sporting Regulations of the following three National Sporting Authorities (ASNs): RACB, KNAF and DMSB.

It will be run in conformity with these Sporting and Technical Regulations, and the FIA Appendix J (Art. 277).

The 2026 PRTB season consists of nine rounds, held at five rally events. During the final round of the season, points will be awarded with a double multiplier.

The Trophy is supported by the following companies and/or products:

- Michelin ;
- Mobil 1 ;
- D’Ieteren Porsche Import ;

With the signing of the “entry form”, each Competitor and Driver participating in the PRTB acknowledges having read these regulations and agrees to comply with all their provisions, including those issued by the ASNs and by the FIA International Sporting Code and its appendices.

In these regulations, terms referring to natural persons apply equally to all genders.

2 ORGANISATION

2.1 Series Organiser

Cup Challenge Benelux BV., hereinafter called the Series Organiser, is hosting the Porsche Rally Trophy Benelux in 2026.

Cup Challenge Benelux B.V.
Maastricht Randwyck
Robert Schumandomein 2
6226 ES Maastricht
The Netherlands
T+31 (0)43 790 1000

Contact:

Mr. Yves Matton – Series Manager
E-Mail: yves.matton@prospeed.be

Julien Frère – Trophy Sporting Coordinator
Mobile : +32 479 97 28 71
E-Mail : julien.frere@prospeed.be

Technical Manager :

Lionel Hansen — Head of Technical Development

E-Mail : lionel.hansen@prospeed.be

Etienne Ploenes – Technical Coordinator

Etienne Ploenes

Email : etienne.ploenes@prospeed.be

Prospeed Motorsport –Spare Parts Sales :

Peter Reyniers

Tel. : + 32 (0)11 93 61 37

E-mail : peter.reyniers@prospeed.be

2.2 Parent ASN

RACB – Royal Automobile Club de Belgique

2.3 ASN Visa/ Registration Number

The Porsche Rally Trophy Benelux based on these Sporting and Technical Regulations has been approved by the RACB on the date with permit number indicated in the footnote of this document.

2.4 The Organising Committee

(except where otherwise specified in the Team Information relating to the event concerned).

The Organising Committee is composed of the following persons :

- Yves Matton, Series Manager – PRTB ;
- Lionel Hansen, Head of Technical Development – PRTB ;
- Julien Frère, Sporting Coordinator – PRTB.
- Etienne Ploenes, Technical Manager – PRTB ;

Members of the Organising Committee may delegate functions and responsibilities where appropriate to other employees of Dr. Ing. h.c. F.Porsche AG, and Dr. Ing. h.c. F.Porsche AG may nominate additional members of the Organising Committee where necessary.

The address of the Organising Committee is that of the Series Organiser (cf. Art. 2.1).

2.5 The Sporting Committee

The Sporting Committee for the Porsche Rally Trophy Benelux will be established comprising of the following people or their nominated representatives:

- The Trophy Organiser ;
- The Trophy Series Manager ;
- The Trophy Technical Manager ;
- The Trophy Sporting Coordinator ;
- The Head of Technical Development.

The Trophy Sporting Coordinator may assist Competitors in understanding and applying the present regulations and may, where appropriate, provide recommendations.

The Sporting Committee shall be competent to decide on any matter relating to the interpretation and application of these Sporting and Technical Regulations, insofar as such matters do not fall within the exclusive competence of the Event Officials or by the Stewards.

The Sporting Committee reserves the right to take any measure specific to the Porsche Rally Trophy Benelux in the event of a breach of obligations related to the Trophy, including but not limited to the Porsche Code of Conduct (Art. 4.1), the provisions of these regulations, and any contractual or promotional obligations. Such measures fall exclusively within the organisation and management of the PRTB and are separate from and independent of any decisions taken by the Event Officials or by the Stewards.

The decisions of the Sporting Committee shall be final and shall not be subject to any protest or appeal.

In the event of a disqualification of a Competitor imposed by the Stewards for technical non-compliance, no points, classification, prize or award shall be granted to the Competitor within the framework of the PRTB for the event concerned. It is specified that disqualification falls within the sole discretion of the Stewards and does not constitute an automatic sanction.

Where such disqualification for technical reasons occurs during the second leg of a rally, all points, classifications, prizes and awards obtained during the first leg shall be cancelled. In all other cases, these shall remain valid unless otherwise decided by the Sporting Committee, with duly stated reasons.

3 DEFINITIONS

For the purposes of these regulations, the following terms and expressions shall have the meanings set out below :

National Sporting Authority (ASN) : Body recognised by the FIA to exercise the sporting authority for motor sport in a given country.

Royal Automobile Club of Belgium (RACB) : National Sporting Authority recognised by the FIA for Belgium.

Koninklijke Nederlandse Autosport Federatie (KNAF) : National Sporting Authority recognised by the FIA for the Netherlands.

Deutscher Motor Sport Bund (DMSB) : National Sporting Authority recognised by the FIA for Germany.

Fédération Internationale de l'Automobile (FIA) : International organisation governing motor sport and recognised as the supreme authority in this field, notably responsible for the drafting and application of the International Sporting Code.

Belgian Rally Championship (BRC) : Belgian Rally Championship.

Deutsche Rallye-Meisterschaft (DRM) : German Rally Championship.

Open Nederlands Rally Kampioenschap (ONRK) : Dutch rally championship open to foreign participation.

One-Make Series (OMS) : Single-make competition series organised by or on behalf of Porsche AG, using vehicles of identical specifications.

Porsche Rally Trophy Benelux (PRTB) : Single-make series (OMS) intended for registered Competitors, using exclusively 911 GT3 Cup with Rally GT® Kit compliant with the technical regulations of the Trophy.

Trophy Organiser : Entity responsible for the organisation of the Porsche Rally Trophy Benelux, namely Cup Challenge Benelux B.V.

Porsche Motorsport : Entity of the Porsche AG group responsible for motorsport activities.

Competitor : Any natural or legal person entered in the Trophy, referring indistinctly to the crew and/or the team responsible for entering a vehicle.

Driver / Co-Driver : Persons holding a valid licence and authorised to drive or occupy the vehicle entered in the Trophy.

Team : Technical structure or entity responsible for the preparation, servicing and sporting operation of one or more vehicles entered in the Trophy.

Technical Delegate : Licensed scrutineer appointed by RACB Sport and/or by the Trophy Organiser, responsible for the technical checks specific to the Porsche Rally Trophy Benelux.

Power Stage : Special stage designated for the allocation of specific Porsche Rally Trophy Benelux points, as defined by the rally organiser or, failing that, by the Trophy Organiser.

Team Information : Official information bulletin issued by the Trophy Organiser before and/or during an event, specifying practical, organisational and sporting information for Competitors and crews.

Vehicle homologation – reference PORSCHE 911 RALLY GT®: RACB homologation form B-2025-01 and its Variant Options (VO), covering a fully homologated competition vehicle as well as all its specific components used in rallying.

4 APPLICABLE REGULATIONS AND LEGAL BASIS OF THE TROPHY

4.1 Porsche Rally Trophy Benelux Code of Conduct

The PRTB is a Trophy characterized by equality of opportunity and fairness – in both technical and sporting terms. Those involved in the Trophy, i.e., Competitors, Teams with all employees and team members, Drivers, officials and organisation, make a significant contribution to how the Series is perceived – both internally and by the general public – and to the atmosphere in the Series through their conduct and their communication.

All those involved are responsible for conducting themselves in such a way as to uphold and safeguard in the long term the professionalism that prevails in the Trophy, as well as the esteem in which the Trophy and its Competitors are held by the general public. Moreover, fair and sporting competition represents an important safety aspect for all Competitors and is intended to avoid risk factors. For this reason, all those involved agree to acknowledge the philosophy of the PRTB and to comply with the rules of conduct of the Trophy.

Both on and off the rallies, all those involved will:

- treat all Competitors, officials and the organisers respectfully ;
- follow the laws and the rules of the sport, exemplify and promote fairness and the rules of conduct ;
- neither express themselves or behave in an insulting, offensive or abusive way, nor tolerate such expressions or modes of conduct, either in direct conversations, interviews, etc. or in other communication, e. g. press releases, posts in social media, etc. ;
- always behave in the interests of safety and permanently cooperate in efforts to reduce risks ;
- use resources in a sustainable way, giving priority to the well-being, safety and satisfaction of others before their own personal goal ;
- always comply with the purpose of the sport ;
- inform those involved if their conduct is not characterized by fairness, sportsmanship, respect and tolerance ;
- cooperate with all other persons involved to develop and improve the Trophy and its status further on a continuous basis ;
- respect the laws and local customs in the countries visited by the Series ;
- comply with the time schedules and any specific provisions set by the organiser ;
- respect local residents and their property, as well as other road users ;
- respect the visual identity associated with all PRTB materials ;

The above list is not exhaustive and any behaviour contrary to the spirit of the Trophy may be considered a violation of this Code of Conduct.

Any breach of the above-mentioned principles and obligations may result in the application of the measures provided for in Article 13 of these Regulations.

Specific requirements or restrictions relating to the conduct of Competitors, as well as particular conditions of participation, may be issued by the Trophy Organiser in order to minimise risks and ensure protection against any infectious disease, epidemic or pandemic posing a risk to public health. Competitors are responsible for ensuring that these requirements are fully complied with by any person associated with their entry.

4.2 Regulations and documents applicable

The Trophy is governed by the following regulations and documents. In order to avoid any ambiguity, in the event of any inconsistency or conflict between the applicable regulatory texts, the following order of precedence shall apply:

1. FIA International Sporting Code and its appendices ;
2. The applicable National Sporting Codes of RACB, KNAF and DMSB ;
3. The Porsche Rally Trophy Benelux 2026 Sporting Regulations;
4. The Porsche Rally Trophy Benelux 2026 Technical Regulations;
5. The Sporting and Technicals Regulations of the Belgian Rally Championship (BRC), the Standard Regulations for Rallying in the Netherlands and the regulations of the Deutsche Rallye-Meisterschaft (DRM), depending on the event concerned ;

6. The RACB GTP Technical Regulations ;
7. The Supplementary Regulations of the event concerned, including any appendices or amendments, as published by the event organiser ;
8. The *Team Information* issued by the Trophy Organiser.
9. The vehicle homologation form – reference: RACB B 2025-01 + VO

4.3 Entry into Force and Amendments to the Regulations

Any amendment to these Regulations must receive prior approval from RACB Sport and shall be issued in the form of a dated and numbered addendum.

Anything not expressly authorised by these Regulations is prohibited.

4.4 Official Language and Interpretation

Only the English text is binding.

In case of interpretation, the RACB jurisdiction is the responsible authority.

5 CALENDAR

The Porsche Rally Trophy Benelux will be contested over five rally events according to the following calendar:

Date	Event	Country
25–26 April	Rallye de Wallonie	Belgium
26–27 June	Ypres Rally	Belgium
10–11 July	GTC Rally	Netherlands
14–15 August	Saarland-Pfalz Rallye	Germany
26 September	East Belgian Rally	Belgium

The organiser of the event concerned and the Trophy Organiser reserve the right to cancel an event, modify its format or change its location, subject to the approval of the competent RACB where the official Trophy calendar is affected.

In the event that one or more rallies included in the calendar are not organised, the Trophy Organiser will examine, in cooperation with the relevant ASNs (RACB, KNAF or DMSB), the possibility of proposing a replacement event.

If no replacement event can be found, any reduction of the calendar shall not give rise to any compensation, reimbursement or financial indemnity of any kind, which shall in no circumstances be claimed by the Competitors or the teams.

6 ENTRIES

6.1 Eligibility – General Provisions

The PRTB is open to teams and drivers of all nationalities, provided that they hold a valid licence compatible with the rallies included in the calendar. There is no maximum age limit for participation in the Trophy.

The Trophy Organiser reserves the right to review any entry application submitted by a driver or a team wishing to enter one or more vehicles in the Trophy.

Admission is subject to:

- strict compliance with the sporting and technical regulations of the Trophy ;
- the exclusive use of parts and components compliant with the specifications defined by the Trophy Organiser ;
- compliance with technical fairness and the image of the Trophy ;
- compliance of the chassis number, valid vehicle registration, and adherence to applicable road traffic regulations.

6.2 Entries and Closing Date for Entries

The entry application for the PRTB must be submitted by the Competitor using the official “entry form” provided by the Trophy Organiser. This application must be received by the Trophy Organiser no later than 10 working days before the first rally in which the Competitor wishes to participate.

6.3 Representation of the car

Each car must have a representative, which must be designated in writing on the entry form.

If a representative is unable to be personally present during a competition, they must designate their representative(s) in writing to the Sporting Comitee.

The representative of an entered car shall, at all times during the competition, be jointly responsible with the Competitor for compliance with all requirements of these Regulations.

6.4 Acceptance and Refusal of Entries

The Trophy Organiser reserves the right to refuse any entry application at its sole discretion, stating the reasons for such refusal. No automatic right to acceptance or participation in the Trophy is granted.

Acceptance of the entry shall be notified in writing and accompanied by an invoice relating to the entry fees.

This invoice must be paid in full no later than seven days after the date of issue and, in any event, no later than the day before the official ceremonial start of the rally concerned.

Effective participation in the PRTB shall only be confirmed after :

- receipt by the Trophy Organiser of the full payment of the corresponding entry fees ; and
- payment of all outstanding invoices due to Cup Challenge Benelux B.V., Prospeed Engineering, Prospeed Competition, Porsche AG, Porsche Motorsport, their respective affiliates and, more generally, to any official commercial partner of the Trophy.

In the event that an application for participation is refused, the Competitor will be informed no later than ten days after receipt of the entry, and Cup Challenge Benelux will reimburse any entry fees already paid by bank transfer. In accordance with Article 3.14 of the Code, the refusal shall be reasoned.

All applications must be duly completed, signed by the Competitor, and sent to the following address:

Cup Challenge Benelux B.V.
Maastricht Randwyck
Robert Schumandomein 2
6226 ES Maastricht
The Netherlands
Mail: julien.frere@prospeed.be

6.5 Drivers

6.5.1 Classified Drivers

Drivers duly entered and not subject to any specific restrictions are eligible for the Trophy classifications, points, prizes and awards.

6.5.2 Masters Drivers

Drivers who are aged 50 or over on 1 January of the current year are eligible for the overall Masters classification (see Art. 13.4).

6.5.3 Non-classified Drivers

Drivers listed on a priority list of an ASN and/or the FIA, as well as those who have been national rally champions (tarmac and/or gravel) or winners of at least one round of a national championship since 2020, are authorised to participate in the Porsche Rally Trophy Benelux.

These drivers will appear in the overall PRTB classification of the relevant rally but will not be eligible for the allocation of points or the awarding of prizes in the Trophy.

They will be considered transparent for the allocation of points and prizes.

By way of exceptional derogation, and for duly justified reasons, the Sporting Committee defined in Article 2.5 of the present regulations may authorise such a driver to be eligible for points and prizes. Any decision taken in this respect shall fall within the discretionary power of the Sporting Committee, shall not be subject to appeal, and shall not constitute a precedent.

6.5.4 “Guest / VIP” Drivers

The Sporting Committee, as defined in Article 2.5 of the present regulations, reserves the right to authorise one or more drivers to participate in the Trophy as “Guest / VIP” drivers.

Any driver designated as “Guest / VIP” will be officially notified prior to the start of the event by means of a *Team Information* bulletin.

These drivers will appear in the overall PRTB classification of the relevant rally but will not be eligible for the allocation of points or the awarding of prizes in the Trophy.

They will be considered transparent for the allocation of points and prizes.

6.6 Entry Fees and Conditions

6.6.1 Entry Modalities

Competitors in the PRTB may enter under one of the following modalities :

- **As a Driver**, on an individual basis, to be eligible for the Drivers and/or Masters classifications;
- **As a Team (per car)**, to be eligible for the Teams classification.

A Team may have different drivers compete throughout the season and shall designate, for each rally, a maximum of two drivers eligible to score points in the “Teams – PRTB” championship.

A Team entering more than two cars in the same rally may create one or more additional entities under a distinct designation of its choice (e.g. “Team X”, “Team X B”, etc.) in order to nominate one or two additional drivers eligible to score points. In such case, these drivers shall score points exclusively in the name and on behalf of the entity under which they are entered, each entity being considered as a separate Team for the purposes of the “Teams – PRTB” classifications.

A driver designated by a Team to participate in a rally of the Trophy is not required to register individually as a Driver. Such driver shall automatically be eligible to participate in the Trophy for the relevant event, subject to compliance with the eligibility conditions set out in these Regulations.

Entry as a Team is made on a per-car basis and may be used by the Team as part of its commercial activities, including, but not limited to, car rental operations.

Points, classifications, prizes and awards related to the Teams classification shall be awarded to the Team, regardless of the identity of the driver entered at each event.

6.6.2 Entry Fee

The following entry fee apply to all Competitors :

- Entry Fee – Driver **500 EUR** (excl. VAT)
- Entry Fee – Team (per car) **500 EUR** (excl. VAT)

This flat fee remains the same regardless of the number of rallies in which the Competitor takes part during the season (whether participating in one or multiple events).

No refund will be granted in the event of partial participation or non-participation.

6.6.3 Included Services and Benefits :

The entry fees include, for each event, the following services and benefits:

- Technical support, including monitoring and updates, ensuring performance and equality between all Competitors;
- Spare parts service provided through an on-site parts truck at each event;
- Sporting support and assistance to Competitors provided by the PRTB Organisation, including the Sporting and Technical Coordinators of the Trophy;
- Dedicated PRTB classifications (Drivers / Teams / Masters / Power Stage);
- Access to the PRTB hospitality area (drinks and snacks) for up to six persons;
- Two official “Porsche Rally Trophy Benelux” clothing kits (jacket + polo shirt);
- One official “Porsche Rally Trophy Benelux” beach flag;
- Automatic entry into a draw offering a free entry to each rally;
- Eligibility for prizes and awards as defined in Article 15 of these Regulations;
- Access to dedicated testing sessions or shakedown (subject to availability);
- Communication and promotional activities (videos, photos, social media, press releases, conferences, etc.).

The Organiser reserves the right to modify, supplement or adapt the services and benefits depending on the specific characteristics of each event. This list is indicative and non-exhaustive; detailed provisions will be specified in the applicable PRTB *Team Information* bulletins.

6.6.4 Optional Benefits at Preferential Rates

Competitors are entitled to purchase the following at preferential rates :

- FIA-homologated “Porsche Rally Trophy Benelux” racing suit, including flame-resistant underwear (top), compliant with Appendix L of the FIA International Sporting Code, from the Trophy’s official apparel partner;
- Official “Porsche Rally Trophy Benelux” clothing kits (jacket + polo shirt);
- Meals within the PRTB hospitality area;
- Additional access passes to the PRTB hospitality area;
- Equipment (helmets, fireproof underwear, Frontal Head Restraint (FHR) systems) from the Trophy’s official equipment partner;
- Technical support services (including technicians and engineers), available upon request and subject to separate invoicing.

The detailed conditions and prices applicable to these preferential rates are set out in Appendix 1 of the present Regulations.

6.7 Entries for the Individual Rallies

The entry fee grants access to the Porsche Rally Trophy Benelux and its associated benefits but does not include the entry fees of individual rallies, which remain payable to each event organiser.

By the closing date for entries for each rally, the Competitor must send a copy of the official entry form for the rally concerned to the Trophy Organiser by email to the attention of Julien Frère:

julien.frere@prospeed.be

Failing this, the Trophy Organiser reserves the right to refuse the driver's participation in the Trophy.

The PRTB Organiser does not guarantee a Competitor's inclusion on the official entry list of a rally.

6.8 Communication with Competitors

Competitors duly entered must have a valid email address capable of receiving messages with a minimum size of 2.5 MB, as well as a telephone number allowing the use of the WhatsApp application.

Official Trophy information is communicated exclusively via the Sportity application.

7 ELIGIBLE VEHICLES AND EQUIPMENT

7.1 Eligible Vehicles

Participation in the PRTB is restricted to competitors using a **911 GT3 Cup with Rally GT® Kit** compliant with the 2026 Porsche Rally Trophy Benelux Technical Regulations, the 2026 Technical Regulations of the group or class in which the car is entered, and RACB homologation form B 2025-01, including its extensions.

No other vehicle model is permitted to participate in the Trophy.

7.2 General Conditions for Vehicle Eligibility

All vehicles entered in the Trophy must: :

- comply with the applicable technical and administrative requirements of the competent ASN, depending on the country in which the vehicle is registered ;
- for vehicles registered in Belgium, comply with the provisions set out in Article 12 of the Sporting Regulations of the Belgian Rally Championship (BRC) ;
- have been presented and approved during the scrutineering of the event concerned ;
- comply with the vehicle identification plan as defined in Article 8.1 of these Regulations 1;
- comply in all respects with the 2026 PRTB Technical Regulations, the 2026 Technical Regulations of the group or class in which the car is entered, and RACB homologation form B 2025-01, including its extensions.

The presentation of the vehicle at scrutineering constitutes an implicit declaration of compliance by the Competitor.

8 ADVERTISING, IDENTIFICATION AND USE

8.1 Car Identification

The vehicle identification, as defined by Cup Challenge Benelux and detailed in Appendix 2 to the present Regulations, is mandatory and shall not be modified under any circumstances.

The Trophy Organiser and its partners shall provide the Competitors with the advertising stickers required in accordance with the aforementioned plan.

The Trophy Organiser reserves the right to add additional partners to this list.

Throughout the entire duration of the rally, the vehicles must carry all the required identification and be presented in an impeccable condition, notably at the start of the event and upon entry into the final parc fermé.

8.2 Use of Rights

Cup Challenge Benelux, Porsche Motorsport and the sponsor partners of the PRTB reserve the right to use, for advertising, promotional or commercial purposes, the names, sporting results, images, photographs, voices and statements of the Competitors, drivers, co-drivers and teams participating in the Trophy, without prior authorisation and without payment of any rights or fees.

By the mere fact of their registration, the Competitors, drivers, co-drivers and teams expressly authorise such use and the transfer of these rights to third parties, without limitation in time or territory.

9 SERVICE PARK

In agreement with the organisers of the various events, a PRTB Service Park is established and reserved exclusively for Competitors duly entered in the Trophy for each rally included in the 2026 calendar.

Unless otherwise authorised by the Trophy Organiser, all Trophy Competitors must use the dedicated Service Park.

When entering each rally, the Competitor must order the required service area from the Trophy Organiser. The Trophy Organiser centralises all requests and forwards them to the organiser of the rally concerned.

The standard service area per crew is set at 8 × 6 metres. The rally organiser and the Trophy Organiser reserve the right to review and, where appropriate, refuse any request for a service area considered excessive or unreasonable.

The Trophy Organiser shall under no circumstances be held responsible for the absence of an order or for a late order of the service area by the Competitor.

Within the service area dedicated to the PRTB, no promotional or advertising material competing with that of the official partners of the Trophy is permitted.

A hospitality structure is set up at each round of the PRTB. Access is reserved for each entered crew with a maximum of four persons associated with it. Additional passes may be purchased from the PRTB organisation.

10 SPECIFIC TECHNICAL CHECKS

In addition to the scrutineering procedures provided for in the Supplementary Regulations of each event, specific technical checks relating to compliance with the PRTB Technical Regulations may be carried out at any time by Technical Scrutineers duly appointed by the Trophy Organiser. Such checks shall be conducted under the authority of the parent ASN (RACB) and may, in particular, be performed by the Trophy Technical Manager and/or any duly authorised person holding a valid licence.

The presentation of the vehicle at the preliminary scrutineering shall constitute an implicit declaration of compliance by the Competitor.

11 STARTING ORDER

At the first rally of the calendar, the starting order for the first leg shall be established on the basis of a list proposed by the Trophy Organiser.

For the following rallies, the starting order shall be determined on the basis of the provisional classification of the PRTB Drivers' Championship.

Non-classified Competitors and "Guest" drivers shall be integrated in a fair and consistent manner within the starting order, upon proposal of the Trophy Organiser and in consultation with the organiser of the relevant rally. The final allocation of the starting order shall remain under the sole responsibility of the event organiser and/or the competent ASN.

The starting order as established shall not be subject to any protest against the Trophy Organiser.

12 PODIUM CEREMONY

The first three crews in the overall classification of each round, as well as the Team declared winner, shall receive a trophy during the official podium ceremony organised at the end of each round.

The podium ceremony may take place either immediately after the event on the official podium or later during the event on an alternative podium structure, notably within the PRTB hospitality infrastructure, subject to any investigation or decision of the Stewards.

All podium ceremonies shall be communicated to the Competitors by means of a *Team Information*.

The presence of the drivers and/or teams concerned at any announced podium ceremony is mandatory.

The ceremony begins with the ascent to the podium and ends after leaving the podium, once the official group photographs have been taken.

13 CLASSIFICATIONS AND POINTS ALLOCATION

13.1 General Provisions

The PRTB gives rise to the establishment of the following classifications :

- Drivers Overall Classification
- Masters Overall Classification
- Teams Overall Classification

Within the framework of the PRTB, each leg of a rally event included in the calendar is considered as a separate round of the Trophy, for Drivers classification.

Consequently:

- for rallies taking place over a single day, points shall be allocated at the end of the event ;
- for rallies comprising at least two legs, points shall be allocated at the end of each day, results in separate classifications and points allocations.

By way of exception, the final event included in the PRTB calendar shall award double points, based on the classification established at the end of the event, for all Trophy classifications.

The PRTB consists of nine rounds and gives rise to three separate overall classifications established over the entire season.

13.2 Points Allocation – Drivers' Classification

At the end of each leg constituting a round of the Trophy, points shall be awarded to the entered drivers according to their overall PRTB classification, based on the following scale:

1st : 25 points	6th : 8 points
2nd : 18 points	7th : 6 points
3rd : 15 points	8th : 4 points
4th : 12 points	9th : 2 points
5th : 10 points	10th : 1 point

13.3 Power Stage – Drivers' Classification

For each leg (day) of a rally, a Power Stage shall be defined for the purpose of awarding the corresponding points.

When an official Power Stage is organised by the rally organiser, it shall be considered as the PRTB Power Stage for the relevant leg.

In the absence of an official Power Stage, the Sporting Committee shall designate, as the Power Stage, the first pass of the longest special stage of the rally.

The Power Stage classification shall be established by combining:

- the time recorded on the special stage concerned ;
- any time penalties incurred on that stage, including false start penalties.

In order to score Power Stage points, a driver does not necessarily have to appear in the final classification of the rally or of the relevant leg.

If the designated Power Stage is interrupted or subject to the allocation of notional times, points shall only be awarded if all Competitors authorised to start the leg and still running have completed the stage under normal conditions. Failing this, or if sporting fairness cannot be ensured, no Power Stage points shall be awarded for the relevant leg.

In the event of a tie, the general classification at the end of the relevant leg shall be taken into account. In the event of a further tie, the total mileage of best times achieved during the leg shall be decisive.

Power Stage points are awarded **exclusively for the Drivers' Classification**, according to the following scale :

1st : 5 points	4th : 2 points
2nd : 4 points	5th : 1 point
3rd : 3 points	

13.4 Points Allocation – Masters Classification

At the end of each leg constituting a round of the Trophy, points shall be awarded to the entered Masters drivers according to the following scale :

1st : 3 points
2nd : 2points
3rd : 1 point

Only the points awarded in the overall classification of each round shall be taken into account for the Masters classification. Power Stage points are not considered.

If the car is driven by the co-driver during a special stage, no points shall be awarded for the Masters classification.

13.5 Points Allocation – Teams Classification

Points for the Teams classification shall be awarded at the end of each leg on the basis of the PRTB overall classification.

However, the winning Team is determined at the end of the rally, based on the cumulative results of the different stages. As such, a single trophy is awarded at the finish of the rally.

They correspond to the sum of the points obtained by the two best-placed cars nominated of each team, according to the following scale:

1st : 25 points	6th : 8 points
2nd : 18 points	7th : 6 points
3rd : 15 points	8th : 4 points
4th : 12 points	9th : 2 points
5th : 10 points	10th : 1 point

Each Team must communicate to the Trophy Organiser, prior to the official start of each rally, the full details of the two crews nominated to represent its entity for the relevant event.

13.6 Particular Case of Permanent Interruption of a Rally leg

In the event of the definitive interruption of a leg, and provided that a classification has been established, points shall be awarded based on that classification in accordance with the following scale:

- 100% of the points if 75% or more of the total length of the scheduled special stages has been completed ;
- 50% of the points if 50% or more, but less than 75%, of the total length of the scheduled special stages has been completed ;
- No points shall be awarded if less than 25% of the total length of the scheduled special stages has been completed.

Any resulting points fractions shall be rounded to the nearest whole number.

No crew responsible or jointly responsible for the stopping of the race may benefit from this provision.

13.7 Final Classifications of the Porsche Rally Trophy Benelux

13.7.1 Drivers' Final Classification

The final Drivers' classification shall be established on the basis of the seven best results out of the nine rounds of the season.

Power Stage points obtained throughout the season shall be fully taken into account.

The winner shall be the driver who has scored the highest number of points.

In the event of a tie, the ranking shall be determined as follows :

1. the highest number of first places, then second places, then third places, and so on, achieved in the rounds taken into account for the calculation of the total points ;
2. failing this, the total mileage of the best times achieved over the entire season shall be decisive.

13.7.2 Masters Final Classification

The final Masters classification shall be established on the basis of the seven best results out of the nine rounds.

Power Stage points shall not be taken into account.

In the event of a tie, the same tie-breaking criteria as for the Drivers' classification shall apply.

13.7.3 Teams Final Classification

The final Teams classification shall be established on the basis of all results from the nine rallies.

A Team shall be classified provided that at least one of its two cars is classified at the finish of a rally and scores points.

Only the points awarded on the basis of the overall classification of each rally shall be taken into account for the Teams classification. Points awarded for the Power Stages shall not be taken into consideration for the Teams classification.

The winning PRTB Team shall be the one that has accumulated the highest number of points, in accordance with the allocation method defined in Article 13.5 of these Regulations.

In the event of a tie, the number of best finishing positions obtained shall be taken into account.

14 PRIZES AND AWARDS

14.1 General Provisions

PRTB prizes and awards shall be allocated to the driver, the team and/or any other designated beneficiary, provided that the Competitor has given an express, written and signed authorisation.

The beneficiary of the prizes shall be designated at the time of registration for the Trophy.

Any modification during the season must be the subject of a written authorisation addressed to the Trophy Coordinator, specifying the rally from which the modification takes effect.

In order to be entitled to prizes and awards, drivers, Competitors and beneficiaries:

- must not have been disqualified from the event concerned ;
- must have strictly complied with these Regulations, including the identification plans set out in the appendices ;

All amounts referred to in these Regulations, any addendum, or *Team Information* bulletins are exclusive of VAT. Any cash prizes shall be paid exclusively by bank transfer.

The Trophy Organiser reserves the right to set off any prize due against any certain, due and payable debt owed by the Competitor to the competition parts department of Prospeed Competition / Porsche Motorsport.

14.2 Prizes per Round

14.2.1 Tyres Allocation

For each round (leg) of a rally included in the 2026 calendar, the following prizes shall be awarded based on the classification of the relevant leg, among drivers eligible and duly entered in the Porsche Rally Trophy Benelux:

- 1st Four MICHELIN competition tyres ;**
- 2nd One MICHELIN competition tyre ;**

The tyres shall be provided exclusively to the driver or team at the next rally counting towards the Porsche Rally Trophy Benelux, subject to them being listed on the official starting list of that event.

In the event that the allocation is awarded at the final round of the season, the tyres shall be delivered at the end of the relevant event or, failing that, shall be subject to the issuance of a voucher to be used in accordance with the conditions defined by the Trophy Organiser.

14.2.2 Entry Fee Reimbursement

For each rally included in the calendar, the Trophy Organiser shall also offer the reimbursement of the rally entry fee to one crew participating in the Trophy, designated by a random draw.

The draw shall be conducted among all crews appearing on the official list of crews authorised to start the rally concerned.

This draw shall take place in the PRTB hospitality structure prior to the start of the rally.

The presence of both the driver and the co-driver is mandatory. A notification shall be sent to all Competitors via WhatsApp.

14.2.3 Special case of permanent interruption of a rally

In the event of the definitive interruption of a rally, prizes shall only be awarded if at least 50% of the total scheduled special stage mileage has been effectively completed.

14.3 End-of-Season Awards

At the end of the season, the Trophy Organiser shall award the following titles :

- **2026 PRTB Drivers' Champion**
- **2026 PRTB Masters Champion**
- **2026 PRTB Teams Champion**

The following end-of-season awards shall be granted to the champions :

PRTB Championship	Position	Prize
Drivers	1st	One test session with the future “Rally One” + an invitation to the “Porsche Night of Champions” for driver & his codriver
Masters	1st	One test session with the future “Rally One”
Teams	1st	<i>TBC via Team Information Bulletin</i>

These awards are strictly personal, non-transferable, non-convertible and may not be exchanged for cash.

14.4 Official End-of-Season Prize-Giving Ceremony

The awarding of the end-of-season PRTB prizes is conditional upon the mandatory presence of the prize-winning crews and teams at the annual Cup Challenge Benelux prize-giving ceremony.

The date and location of this ceremony for the 2026 season will be communicated at a later stage.

The unjustified absence of a beneficiary from this ceremony may result in the non-award of the corresponding prizes and awards.

15 LIABILITY, INSURANCE AND DISCLAIMER

By registering for the PRTB, the Competitor, the driver and the co-driver acknowledge that they participate in the events at their own risk, that they have been fully informed of the risks inherent in the practice of motor sports and that they accept them with full knowledge of the facts.

Within the limits permitted by the applicable law, they may not hold Cup Challenge Benelux B.V., the Porsche AG Group and its affiliates, RACB Sport, DMSB, KNAF, as well as the partners and suppliers of the Trophy liable for any bodily injury or material damage, whether direct or indirect, suffered or caused in the context of events counting towards the PRTB.

Competitors undertake to take out appropriate insurance cover, in particular personal accident insurance, the Competitor remaining solely responsible for the insurance coverage of their crew.

16 GOVERNING LAW AND JURISDICTION

Any dispute relating to the formation, execution or interpretation of the contractual relationship between the preparer, the Competitor, the driver, the co-driver and/or Cup Challenge Benelux B.V. and Porsche Motorsport shall, in the first instance, be subject to an attempt at an amicable settlement.

Decisions taken by the FIA, the ASNs, their judicial bodies, the Stewards, the Trophy Organiser and their representatives within the framework of their sporting and regulatory functions may not be challenged before civil or criminal courts, nor give rise to any claim for compensation, except in cases of gross negligence or intentional misconduct.

Subject to the above provisions and to the extent that a jurisdiction clause is admissible, Dutch law shall apply and the courts of Amsterdam (The Netherlands) shall have exclusive jurisdiction over any dispute relating to the PRTB.

VISA RACB SPORT : S01/PRTB-B26 DATED 17/04/2026

PORSCHE**RALLY TROPHY
BENELUX****APPENDIX 1 - OPTIONAL BENEFITS AND PREFERRED RATES**

Item	Description	Unit Price (excl. VAT)
FIA "PRTB" race suits + fireproof underwear	OMP One-Art by Spa Racing	1 000 €
Polo	Official "Porsche Rally Trophy Benelux" polo shirt	50 €
Jacket	Official "Porsche Rally Trophy Benelux" jacket	110 €
Additional meals	Hot meals served within the PRTB hospitality structure	25 €
Hospitality access	Additional access to the PRTB hospitality structure (snacks and drinks)	20 € / day
Equipment	Purchase via Spa Racing with PRTB discount	
Dedicated technical support services	Provision of expert advice and on-site support by a dedicated engineer throughout the rally.	Available upon request and subject to separate invoicing

Contact Julien Frère – Trophy Coordinator
 Mobile : +32 479 97 28 71
 E-Mail : julien.frere@prospeed.be

1. OMP ONE ART RACING SUIT

OMP CUSTOMER: _____ TEAM: _____ DRIVER NAME: _____

CUSTOMIZED SUIT CONFIGURATOR



OMP
PRO SPEED
PORSCH
OMP
PORSCH
MOBILITY
OMP
PORSCH
OMP
PORSCH
ONE-ART AIR
IAO-1875

DATE _____ REV. _____

© OMP RACING SPA - ALL RIGHTS RESERVED

THIS DESIGN IS THE INTELLECTUAL PROPERTY OF OMP RACING SPA - ANY REPRODUCTION WITHOUT PERMISSION WILL BE PROSECUTED TO THE FULLEST EXTENT OF THE LAW. By approving this sketch, the customer acknowledges that, during the process of manufacturing, variations may occur in colors and other minor aspects, because of the use of different technologies for the acquisition and reproduction of images, and for the making of the suit itself. OMP is not responsible for such variations and deviations. For further information: www.ompracing.com

2. FIREPROOF UNDERWEAR "PORSCHE RALLY TROPHY BENELUX"



3. POLO "PORSCHE RALLY TROPHY BENELUX"



4. JACKET "PORSCHE RALLY TROPHY BENELUX"



APPENDIX 2 - CAR IDENTIFICATION

Porsche Rally Trophy Benelux

Season 2026

Sticker Regulation

Status 30/03/2026

No.	Quantity	Size (mm)	Colour	Logo / Symbol	Placement
1	1			Reservation RALLY ORGANIZER	Rear window
2	2			Reservation RALLY ORGANIZER	Left and right door
3	2			Reservation PORSCHE; Team is free to use this area but can be reclaimed any time by the series organisation.	A-pillar, left and right
4	1	526 x 29	black or white	Porsche Logotype	Rear lid
5	1	256,5 x 40	black or white	GT3 Cup	Rear lid
6	1	207 x 107	original colours	Flash for current interrupter+ E for extinguisher	Front bonnet, left
7	2		red with white outline	mounting of integral two-mount rescue device	Roof
8	1			Reservation RALLY ORGANIZER	Windscreen, top
9	1	557 x 120	MICHELIN original colours	MICHELIN	Front bumper
10	2			Reservation PORSCHE; Team is free to use this area but can be reclaimed any time by the series organisation.	Area above daytime running light unit
11	1			Reservation REGISTRATION PLATE	Front bumper
12	1	280 x 65	MOBIL1 original colours	MOBIL 1 logo	Front bumper, left and right
13	2			Reservation REGISTRATION PLATE	Rear bumper
14	2	345 x 70	MICHELIN original colours	MICHELIN	Rear bumper, left and right
	2	280 x 65	MOBIL1 original colours	MOBIL 1 logo	
15	2			Reservation PORSCHE; Team is free to use this area but can be reclaimed any time by the series organisation.	Side sill, left and right
16	2				Side sill, left and right
17	2				Side sill, left and right
18	2	280 x 65	MOBIL1 original colours	MOBIL 1 logo	Side sill, left and right
19	2			Reservation PORSCHE; Team is free to use this area but can be reclaimed any time by the series organisation.	Side area, left and right

Please note:

The 'Porsche Rally Trophy Benelux - Sticker Regulations - 2026' is part of the Porsche Rally Trophy Benelux (PRTB) regulations 2026. The advertising decals, logos, and starting numbers as specified by the Series Organiser, must be affixed to all competing vehicles during all official sessions and during test events. The size, type, quantity and positioning are determined further in this document. The sticker regulations are agreed on with the RACB. Any breach of these Regulations may result in the participant concerned being disqualified from classification. All advertising surfaces that are not occupied as specified in the Sticker Regulations are available for the entrants' own advertising labels. The clearance between such advertising and the mandatory stickers shall be a min. 30 mm. The registered entrants will be informed about their starting numbers before the first race. The team (entrant) is responsible for ensuring that the stickers on the entered vehicles comply with the applicable legal regulations. All mandatory stickers are provided by the PRTB, including driver names. Only this version of the mandatory stickers are allowed, copies of the mandatory stickers will be refused. It is forbidden to cut or to modify the dimensions. It's allowed to modify the dimensions of the window banner to avoid an overlay of the A-pillar and roof. All cars must be equipped with the mandatory license plate. The sticker positions 1 - 19 are strictly reserved for Porsche AG and its series- and cooperation partners. Usage of current or historic livery of Porsche Motorsport works racing vehicles is reserved for Porsche AG.

Exclusivity Rule

Advertising of team partners that compete to partners of Porsche AG, Porsche Rally Trophy Benelux and/or cooperation partners shall be prohibited. In regards to the exclusivity of the partners of Porsche AG following rules apply. The exclusivity rule refers to the industry sector or to the product range of a manufacturer.

1. Michelin is the exclusive partner of the Porsche Carrera Cups worldwide and as per contract for several Challenges & Trophies. Therefore it is forbidden to teams to communicate or advertise for companies or products that are competitors of Michelin.

There is no exception for partners of exclusivity.

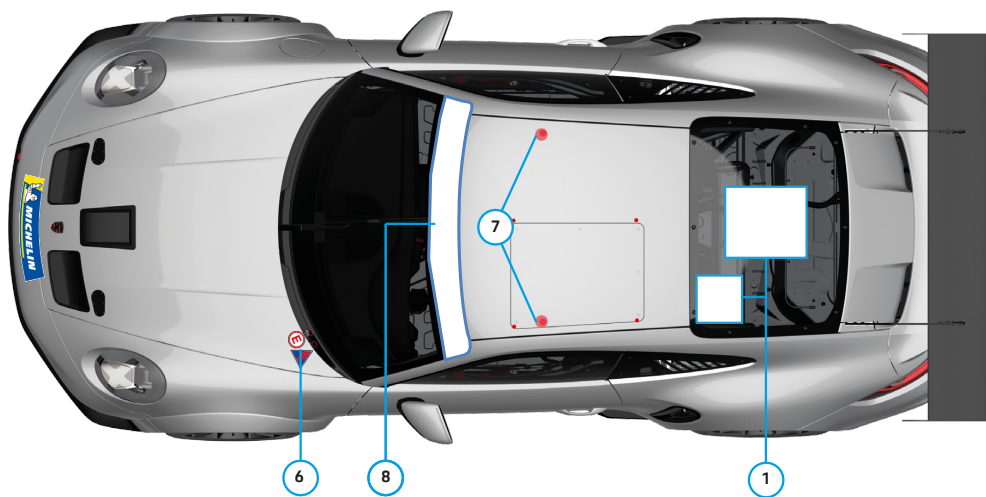
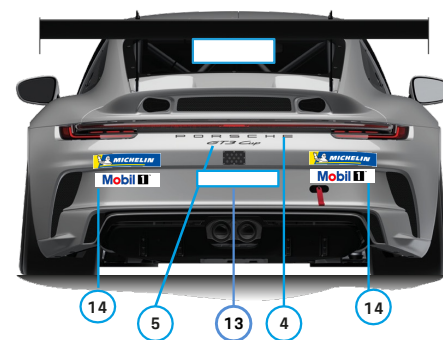
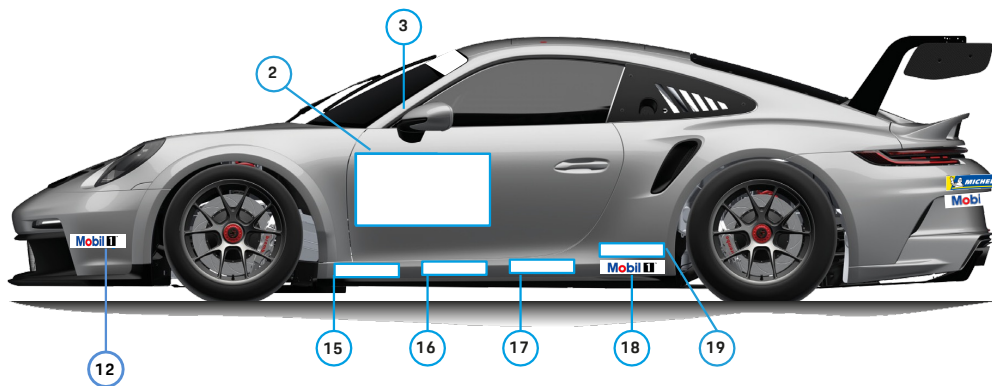
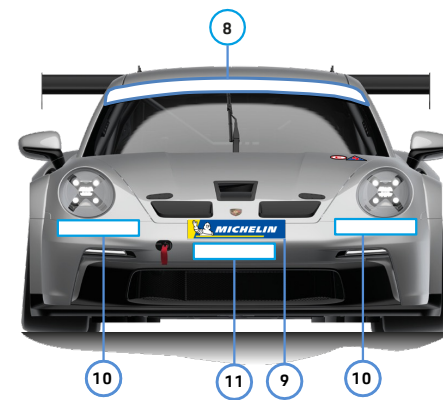
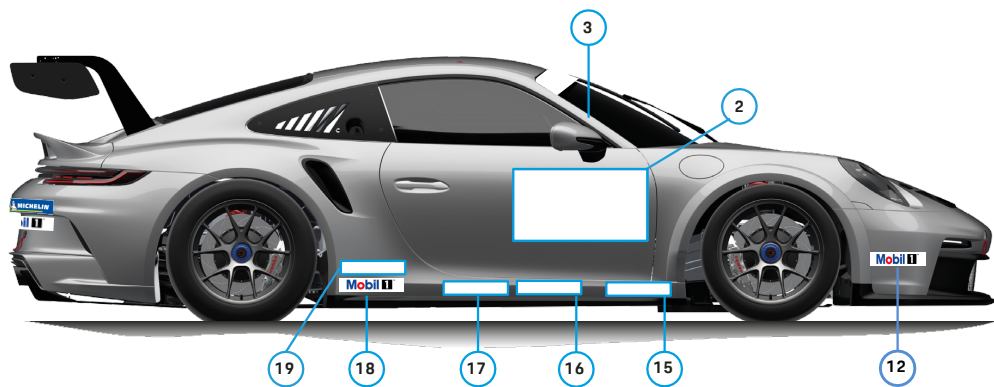

PORSCHE

**RALLY TROPHY
BENELUX**

Sticker Regulation 2026